

Precaution for use ~MOSFET~

1. About structure of the MOSFET and quality improvement

The equivalent circuit of the MOSFET generally becomes like figure 1 and shows it to our data sheet.

It is explained all parts as follows.

(1) MOSFET

We develop MOSFET of the trench structure that is available for the miniaturization of the pattern.

A cross section is shown in figure 2.

A trench is formed in the silicon surface with the trench structure to show it in figure 2. And the sidewall of the trench is used as a channel.

This miniaturization of the pattern is possible with this structure and can realize low ON resistance at the chip size that is smaller than a case of the conventional DMOS structure.

In addition, barrier metal is spread with the aluminum wiring of the Source electrode, and quality reliability improves.

(2) Protection diode of the Gate

The protection diode is formed for ESD protection use of the Gate electrode of the MOSFET.

V_{GSS} is decided by the breakdown voltage of this protection diode.

Because this protection diode is aimed for ESD protection use in case of the handling of the MOSFET, in the surge absorption use with the actual machine, we recommend that Zener diodes are used by attaching externally.

In addition, we develop the product which added resistance to the Gate to improve ability for ESD protection. Please talk about the details with our sales office.

(3) Parasitic diode

It is a diode formed between Drain to Source structurally of the MOSFET. Therefore, it does not take reverse voltage between Drain to Source.

As for this diode, it is not intended to apply an electric current to the forward direction.

When a diode is necessary, we recommend that an external diode is used on a circuit.

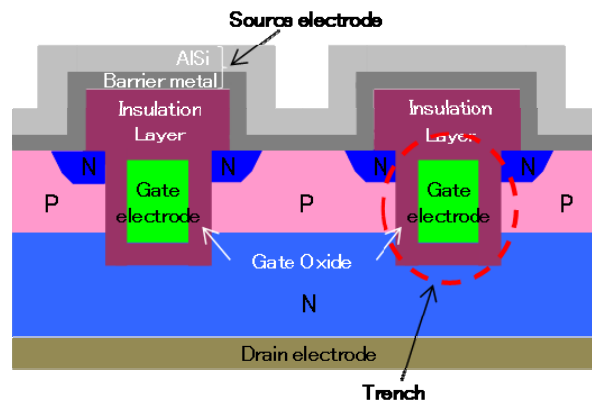
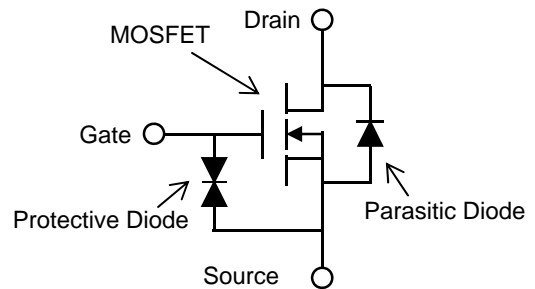

2. About the drive voltage of the MOSFET

The drive voltage of the MOSFET is the smallest voltage that can flow rating Drain current I_D .

Therefore, the use in lower voltage than the specified drive voltage is enabled when Drain current to apply on the circuit is small.

About this matter, we explain a case of INK0010AC1 as an example.

We show I_D - V_{GS} characteristic of INK0010AC1 in figure 3.

The rating of the I_D of INK0010AC1 is 260mA, but, in the case of $V_{GS}=3V$, $I_D=100mA$ is acceptable, and, in the case of $V_{GS}=2.5V$, $I_D = 10mA$ is acceptable.

About other kinds, the drive voltage changes by Drain current used likewise, too. If you have any questions, please talk with our sales office.

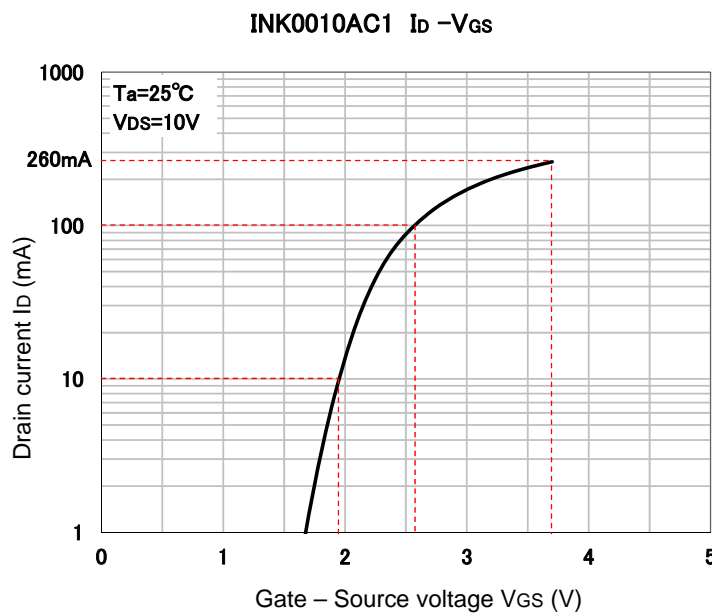

Fig. 3 I_D - V_{GS} characteristic of INK0010AC1

Precaution for use ~MOSFET~

3. About Zener diode built in MOSFET

(1) Avalanche failure

Avalanche failure may occur when MOSFET breaks down due to a surge voltage, which is generated when the switching operation under an inductive load, exceeds Drain-Source breakdown voltage V_{DS} of the MOSFET.

A parasitic element (bipolar transistor /Tr, resistance /R, condenser /C) such as figure 5 is formed in MOSFET structurally.

On the avalanche operation, an electric current showing in figure 5 in a dashed line will flow through parasitic capacity C, and, transistor/Tr turns on in a case beyond the base emitter voltage of Tr the voltage of both ends of resistance R.

At this time, MOSFET is destroyed by an excessive electric current flowing in Tr.

This phenomenon is avalanche failure.

(2) Method to improve avalanche breakdown capability

It is necessary to interfere with working in parasitic transistor /Tr which mentioned above to improve avalanche breakdown capability.

A method to reduce parasitic resistance /R in the case of conventional DMOS structure as these measures is performed. As an example, the sectional structure of the conventional DMOS product is shown in figure 6. Parasitic resistance /R becomes small to show it in the figure by deepening the P-Body region.

The miniaturization of the pattern is necessary to reduce ON resistance of the MOSFET.

Therefore MOSFET of the trench structure that is available for miniaturization becomes mainstream now.

Because it is hard to take measures such as the DMOS structure that we mentioned above in the case of trench structure, different measures are necessary.

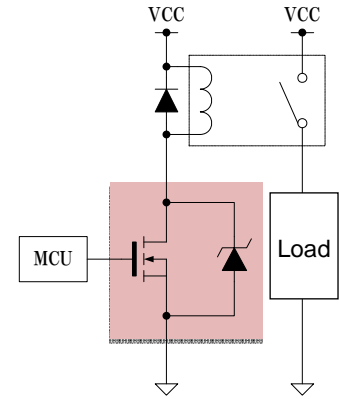

Fig. 4 Drive circuit of the inductive load

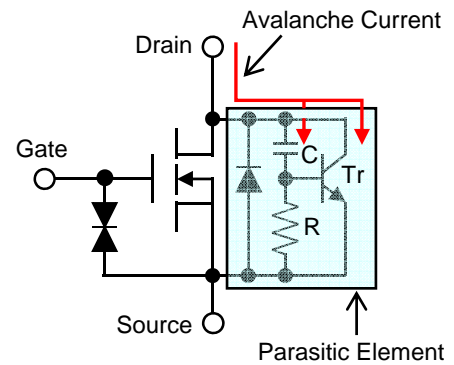

Fig. 5 In case of conventional MOSFET

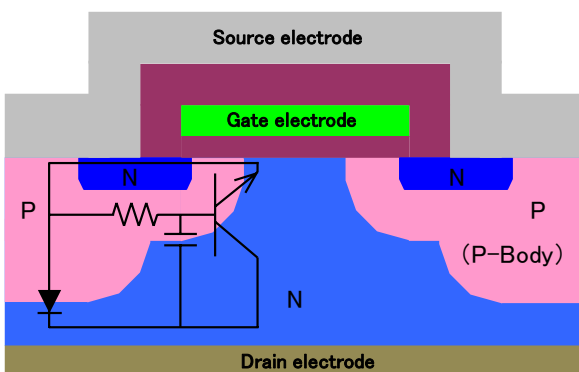

Fig. 6 Cross section of DMOS structure in case of Nch MOSFET

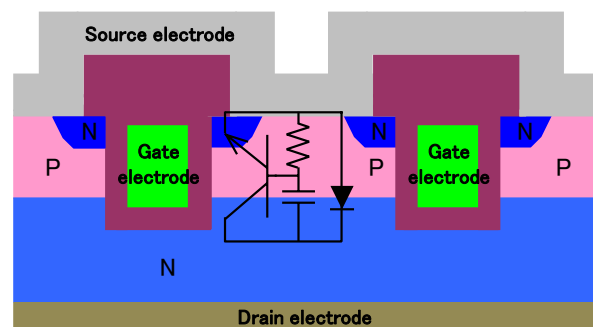

Fig. 7 Cross section of Trench structure in case of Nch MOSFET

Precaution for use ~ MOSFET ~

(3) Development of the Ze diode built in MOSFET

Show in figure 8, we attach Zener diode witch breaks down with the voltage that is lower than V_{DSS} between Drain to Source of the MOSFET to improve avalanche breakdown capability.

In this case an electric current flows through Zener diode before an electric current flows in a parasitic element on the avalanche operation. Therefore, parasitic transistor Tr is hard to be turned on.

This Zener diode is constructed in a silicon chip same as MOSFET. Therefore, the assembling to the small package of 3 pins is possible.

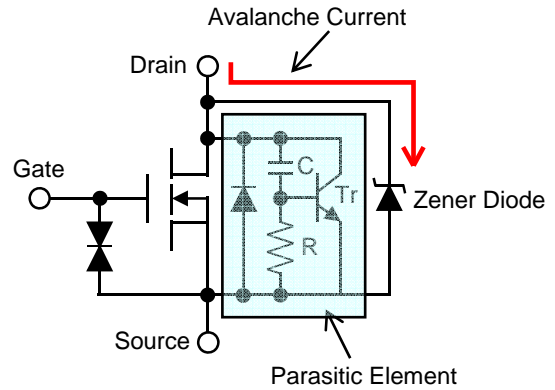

Fig. 8 Zener Diode built-in Nch MOSFET

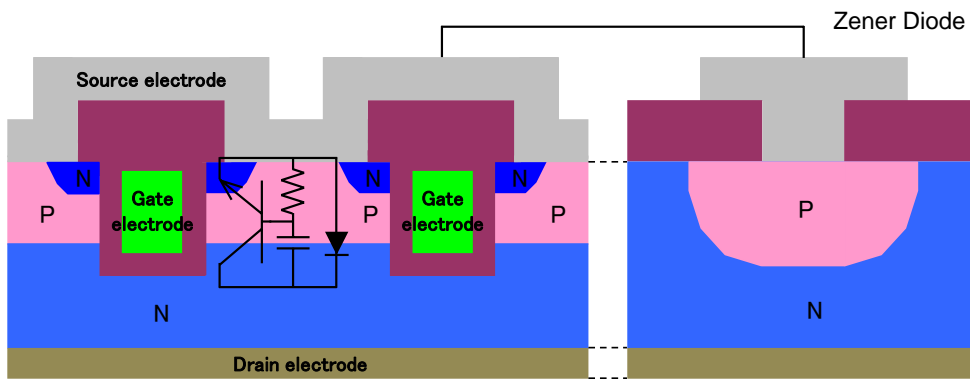

Fig. 9 Cross section of Zener Diode built-in Nch MOSFET

(4) Lineup of the Ze diode built in MOSFET

We are developing three kinds of following products now.

When there is a request, about the product of the standard except this, we examine development.

	$V_{DSS}(V)$	$V_{GSS}(V)$	$I_D(V)$	$V_{th}(V)$	$R_{on}(\Omega)$	Package
INKE111AC1	50 ± 10	± 20	0.5	1.0~2.0	0.6	SC-59
INKE211AC1	50 ± 10	± 20	1.0	1.0~2.0	0.3	SC-59
INKE311AP1	50 ± 10	± 20	2.0	1.0~2.0	0.1	SOT-89

Please refer to our sales office for the demand of the sample.