

RT8H094C

Under development

* This product is under development and may change at a later date.

LED driver circuit with UVLO

DESCRIPTION

RT8H094C is composed by NPN transistors, PNP transistors and resistors. It can miniaturization of a set and reduce parts or time necessary for completion.

RT8H094C constitutes the LED driver circuit. The voltage rise of the resistor RCS connected to the GND side is detected by the CSP terminal, and the LED current is adjusted by comparing it with the built-in voltage of 0.2V.

The off-time can be set by connecting an external resistor and capacitor to the CT terminal.

It is also has a built-in UVLO function to prevent malfunction at 4V or less and thermal shutdown function.

FEATURES

- Miniaturization of a set.
- External setting of a switch-off time is possible with the switch-off time setting terminals (CT).
- Built-on UVLO function and thermal shutdown function.

APPLICATION

- LED driver circuit

OUTLINE DRAWING

Unit : mm

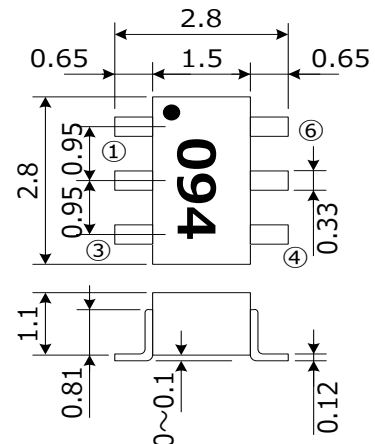

PIN CONFIGURATION

- | | |
|-------|-------|
| ① OUT | ⑥ CSP |
| ② VCC | ⑤ GND |
| ③ CSM | ④ CT |

BLOCK DIAGRAM

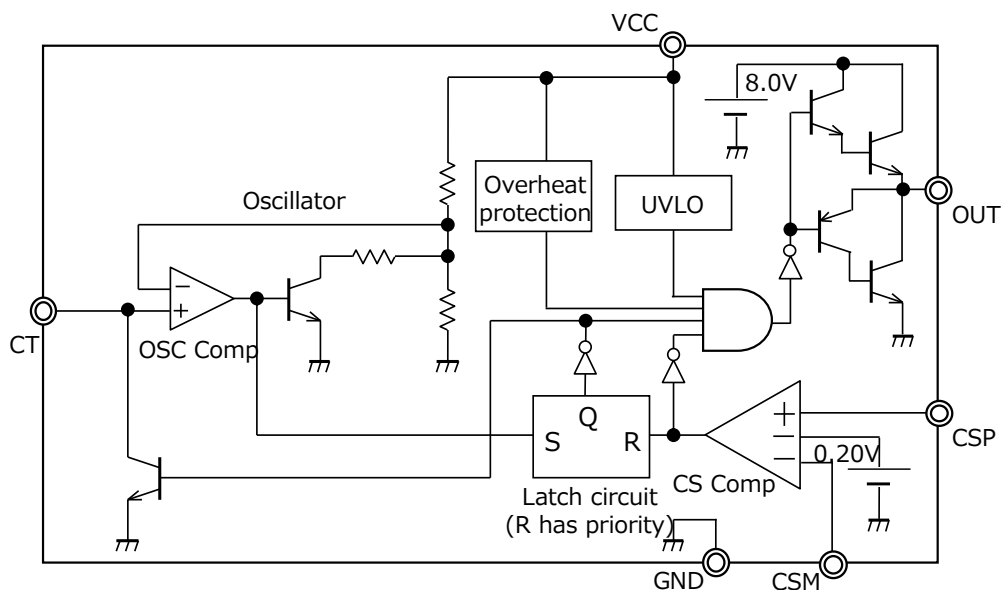

Under development

* This product is under development and may change at a later date.

LED driver circuit with UVLO

ABSOLUTE MAXIMUM RATINGS (Ta=25°C)

Symbol	Parameter	Conditions	Ratings	Unit
VCC	Supply voltage		40	V
IOUT	Output current		10	mA
Pd	Internal power dissipation		200	mW
Kθ	Thermal derating	Ta ≥ 25°C	1.6	mW/°C
Tj	Junction temperature		150	°C
Tstg	Storage temperature	(keep dry)	-40~150	°C
Topr	Operating temperature	(keep dry)	-20~85	°C

RECOMMENDED OPERATING RANGE

Symbol	Parameter	Ratings		Unit
		Min	Max	
VCC	Supply voltage range	4.5	37	V
f	Frequency range	-	200	kHz

ELECTRICAL CHARACTERISTIC (Ta=25°C, VCC=12V unless otherwise noted.)

Symbol	Parameter	Test condition	Designed value			Unit
			Min	Typ	Max	
VCC	Operating supply voltage range		4.5	12	37	V
VCTH1	Operation start voltage		3.91	4.20	4.49	V
VCTH2	Operation stop voltage		3.50	3.85	4.20	V
VCSPTH	CSM threshold voltage		0.188	0.200	0.212	V
ICC1	Circuit current1	CSM:0V, CSP:2V, CT:0V	0.56	0.80	1.04	mA
ICC2	Circuit current2	CSM:OPEN, CSP:0V, CT:5V	0.56	0.80	1.04	mA
IBCSP	CSP bias current	CSM:OPEN, CSP:0V/IM, CT:0V	-300	-120	0	nA
IBCSM	CSM bias current	CSM:0V/IM, CSP:0.2V, CT:0V	-300	-120	0	nA
VTHCT1	CT threshold voltage 1	CSP:0V, CT:0V ⇒ SWEEP(L→H)/IM	2.60	3.10	3.60	V
VTHCT2	CT threshold voltage 2	CSM:0V, CSP:3V CT:VTHCT1 ⇒ SWEEP(H→L)/IM	1.55	1.85	2.15	V
VOSAT1	OUT saturation voltage 1	CSM:OPEN, CSP:0V, CT:0V, OUT:-5mA	5.95	7.00	8.05	V
VOSAT2	OUT saturation voltage 2	CSM:0V, CSP:0.2V, CT:0V, OUT:5mA	0.67	0.75	0.83	V
TOOFF(※)	Switch-off time	RCT=47kΩ, CCT=330pF	-	5.00	-	us
TSD(※)	Thermal shutdown		-	170	-	°C

CHARACTERISTICS

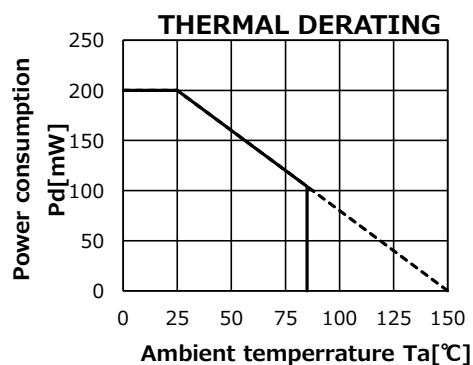

Under development

* This product is under development and may change at a later date.

LED driver circuit with UVLO

APPLICATION CIRCUIT EXAMPLES

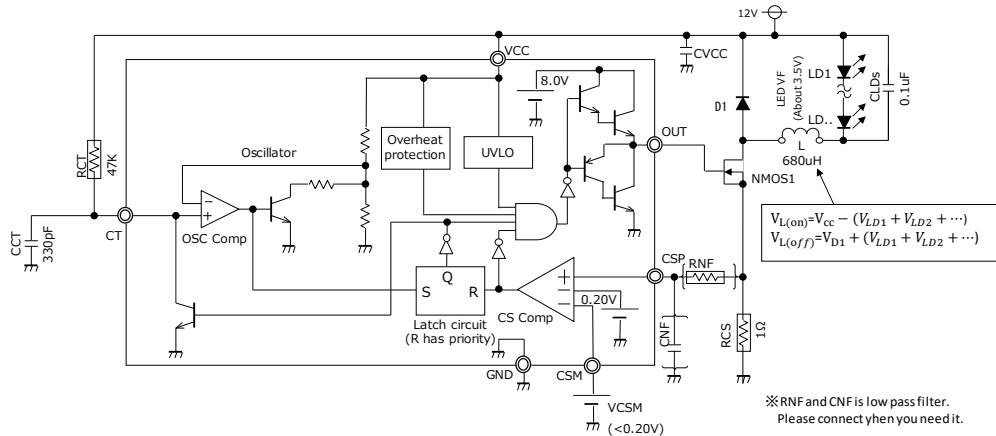

○ Setting off-time (t_{off})

The off-time is determined by the time when the charging voltage of the CT terminal resistor R_{CT} and the capacitor C_{CT} reaches the upper limit of the CT terminal voltage ($V_{CT(H)}$) set inside the RT8H094C.

$$t_{off} = R_{CT} \cdot C_{CT} \cdot \ln\left(\frac{V_{CC} - V_{CT(L)}}{V_{CC} - V_{CT(H)}}\right)$$

($V_{CT(H)}$: CT terminal voltage (output HIGH), $V_{CT(L)}$: CT terminal voltage (output LOW))

○ Setting on-time (t_{on})

$$t_{on} = \frac{L}{V_{L(on)}} (I - I_{min})$$

I_{min} refers to the diode current just before the OUT terminal voltage turns from off to on. The I and I_{min} arithmetic expressions are as follows.

※ The accuracy of I_{ave} is about $\pm 7\%$ only for product variations.

(When the constants of the external components are the above application circuit example.)

$$I = \frac{V_{CSPTH}}{R_{CS}} \quad I_{min} = I - \frac{V_{L(off)}}{L} t_{off} \quad I_{ave} = \frac{I + I_{min}}{2} = \frac{V_{CSM}}{R_{CS}} - \frac{V_{L(off)}}{2L} t_{off}$$

TIMING CHART

(It is based on the application circuit example)

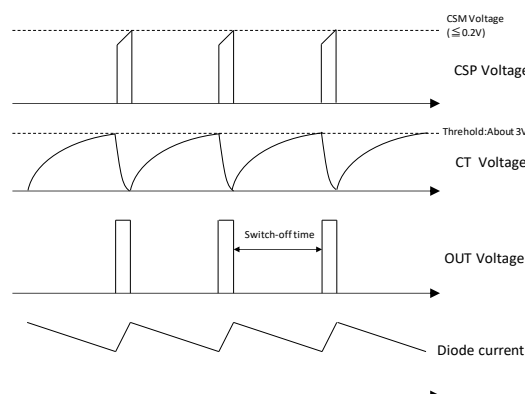

Keep safety first in your circuit designs!

·ISAHAYA Electronics Corporation puts the maximum effort into making semiconductor products better and more reliable, but there is always the possibility that trouble may occur with them. Trouble with semiconductors may lead to personal injury, fire or property damage. Remember to give due consideration to safety when making your circuit designs, with appropriate measures such as (1) placement of substitutive, auxiliary, (2) use of non-flammable material or (3) prevention against any malfunction or mishap.

Notes regarding these materials

- These materials are intended as a reference to our customers in the selection of the ISAHAYA products best suited to the customer's application; they don't convey any license under any intellectual property rights, or any other rights, belonging ISAHAYA or third party.
- ISAHAYA Electronics Corporation assumes no responsibility for any damage, or infringement of any third party's rights, originating in the use of any product data, diagrams, charts or circuit application examples contained in these materials.
- All information contained in these materials, including product data, diagrams and charts, represent information on products at the time of publication of these materials, and are subject to change by ISAHAYA Electronics Corporation without notice due to product improvements or other reasons. It is therefore recommended that customers contact ISAHAYA Electronics Corporation or an authorized ISAHAYA products distributor for the latest product information before purchasing product listed herein.
- ISAHAYA Electronics Corporation products are not designed or manufactured for use in a device or system that is used under circumstances in which human life is potentially at stake. Please contact ISAHAYA Electronics Corporation or an authorized ISAHAYA products distributor when considering the use of a product contained herein for any specific purposes, such as apparatus or systems for transportation, vehicular, medical, aerospace, nuclear, or undersea repeater use.
- The prior written approval of ISAHAYA Electronics Corporation is necessary to reprint or reproduce in whole or in part these materials.
- If these products or technologies are subject to the Japanese export control restrictions, they must be exported under a license from the Japanese government and cannot be imported into a country other than the approved destination. Any diversion or re-export contrary to the export control laws and regulations of Japan and/or the country of destination is prohibited.
- Please contact ISAHAYA Electronics Corporation or authorized ISAHAYA products distributor for further details on these materials or the products contained therein.