

VLB517-01R

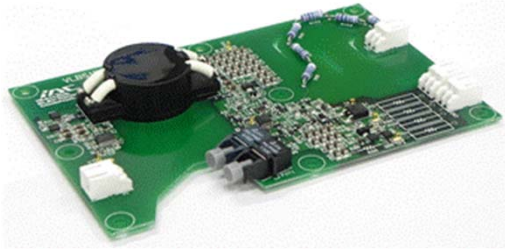

Image photo

FEATURES

- >Single channel simple and easy gate drive system
- >Wire connection to IGBT module
- >Built in the isolated DC-DC converter for gate drive
- >Output peak current is +/-40A(max)
- >Built in short circuit protection with soft shut down
- >Electrical isolation voltage is 10.2kVrms (for 1 minute)
- >Fiber optic interface

TARGETED HVIGBT MODULES

VCES=4500V series up to 1500A class
 VCES=3300V series up to 1800A class

APPLICATIONS

Medium voltage inverter , HVDC infrastructure , Traction or Power supply etc.

OUTLINE

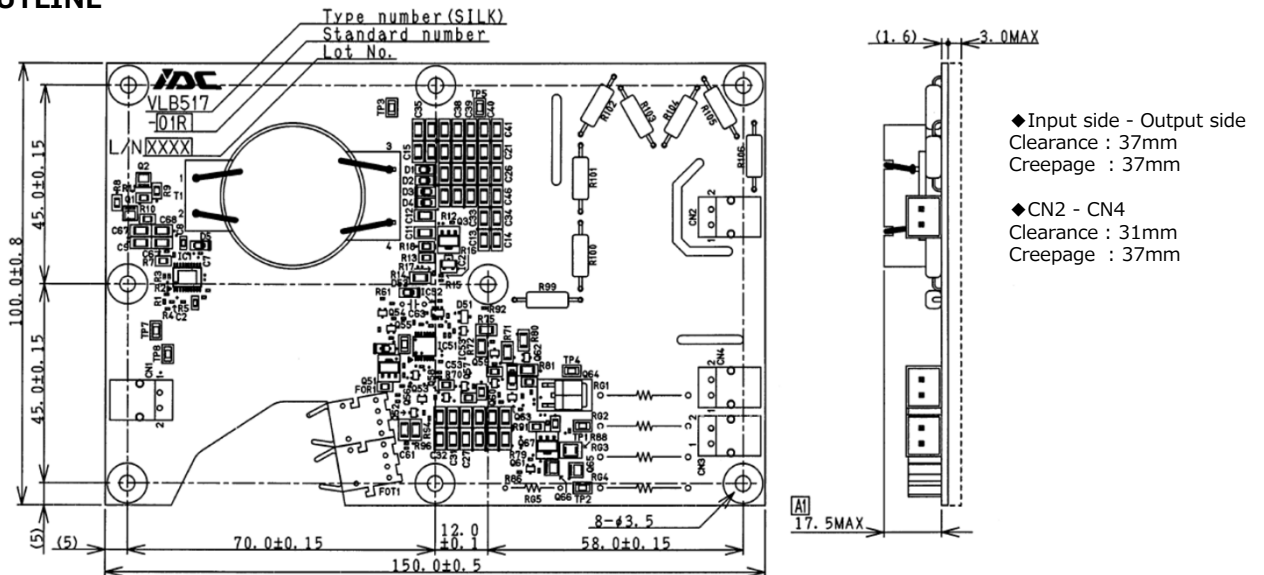

BLOCK DIAGRAM

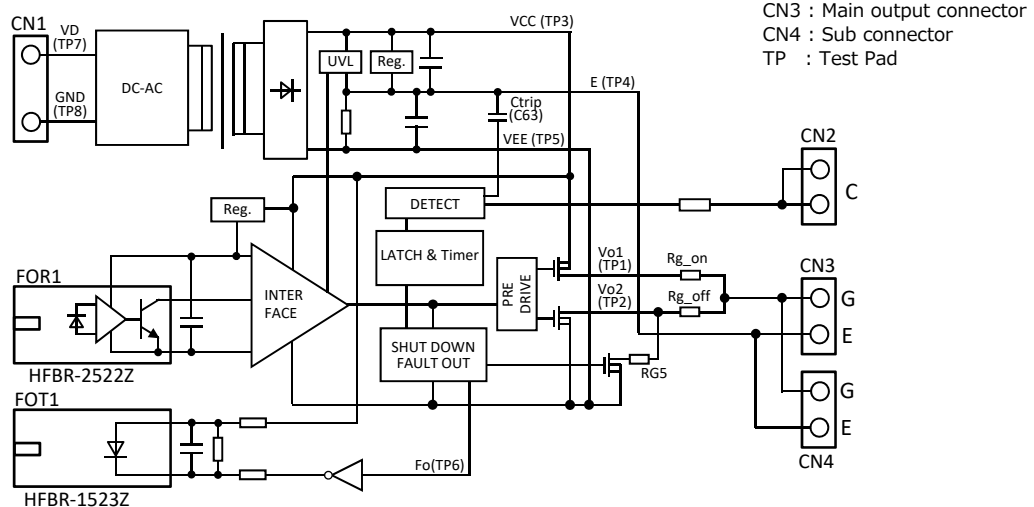

* There are not Rg_on and Rg_off at the initial state. So please solder the chosen resistors.
 * The test pins on the test pad are not installed in mass production.

MAXIMUM RATINGS

(unless otherwise noted, Ta=25 °C)

Symbol	Parameter	Conditions	Ratings	Unit
VD	Supply voltage	Between VD and GND	16	V
IOHP	Output peak current	Pulse width 3us	-40	A
IOLP			40	A
Viso	Isolation voltage between primary and secondary	Sine wave voltage 60Hz, for 1min	10200	Vrms
Tc	Case temperature	Surface temperature of output power MOSFET on substrate	100	deg C
Topr	Operating temperature	No condensation allowable	-40 ~ 85	deg C
Tstg	Storage temperature	No condensation allowable	-40 ~ 85	deg C
Idrive	Gate drive current	Gate average current	200	mA
VC	Peak collector voltage	Peak terminal voltage of CN2	4500	V

ELECTRICAL CHARACTERISTICS (unless otherwise noted, Ta=25°C, VD=15V, Rg_on=Rg_off=1.5Ω, f=3kHz)

Symbol	Parameter	Conditions	Limits			Unit
			Min	Typ	Max	
VD	Supply voltage	Recommended range	14.5	15	15.5	V
f	Switching frequency	Recommended range It is limited by gate average current (max:200mA)	-	-	10	kHz
RG	Gate resistance	Recommended range (Total compound value)	0.1	-	-	Ω
Rs	Soft discharge resistor	Value of RG5, Recommended range	0	-	120	Ω
VOH	Plus bias output voltage	Idrive = 0 ~ 200mA	14	15	16	V
VOL	Minus bias output voltage	Idrive = 0 ~ 200mA	-15	-13	-11	V
tPLH	"L-H" propagation time	IF=30mA, Fiber length=50cm, C_load:0.57uF	-	TBD	-	us
tPHL	"H-L" propagation time	IF=30mA, Fiber length=50cm, C_load:0.57uF	-	TBD	-	us
ttimer	Timer	Between start and cancel of protection (Under input signal is off state)	1	-	2	ms
ttrip	Masked time detect short circuit	Detect terminal (CN2) : over than 190V	-	TBD	-	us
VSC	SC detect voltage	Collector voltage of IGBT	190	-	-	V
UVLO+_VCC	Under voltage lock out (Operation start)	VCC voltage	-	12.6	-	V
UVLO-_VCC	Under voltage lock out (Operation stop)	VCC voltage	-	11.7	-	V

HOW TO CANCEL THE SHORT-CIRCUIT PROTECTION CIRCUIT

The short-circuit protection circuit of this product does not function when the connection of CN2 is open.

CONNECTION EXAMPLE1

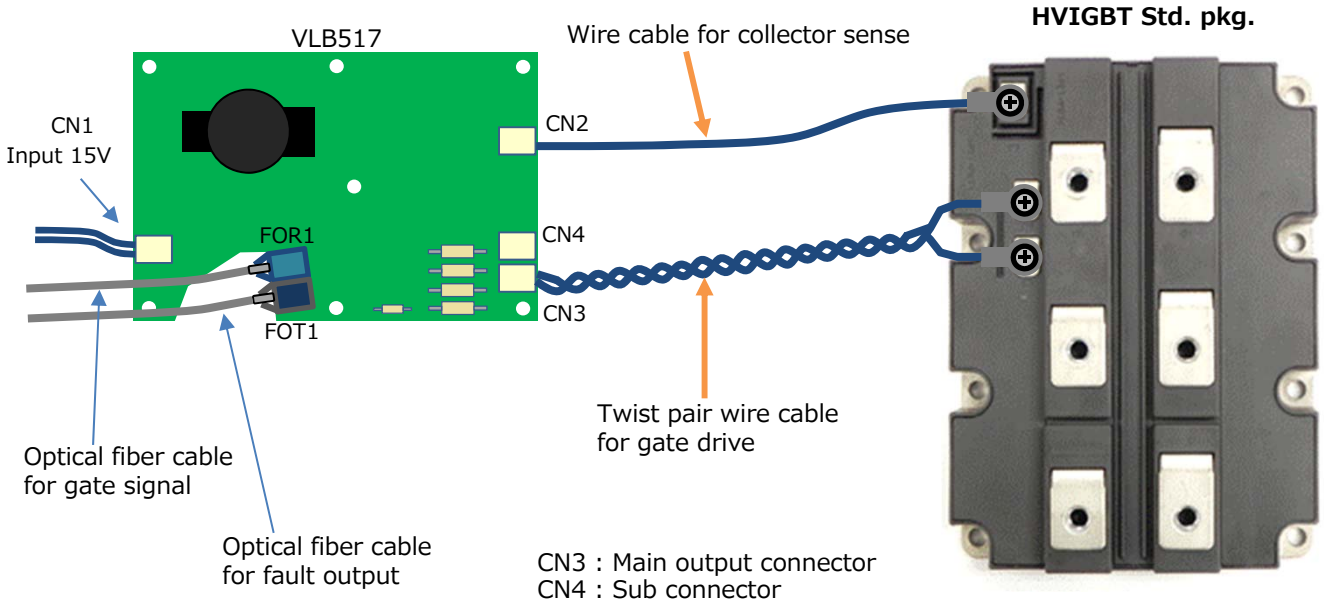

CONNECTION EXAMPLE2

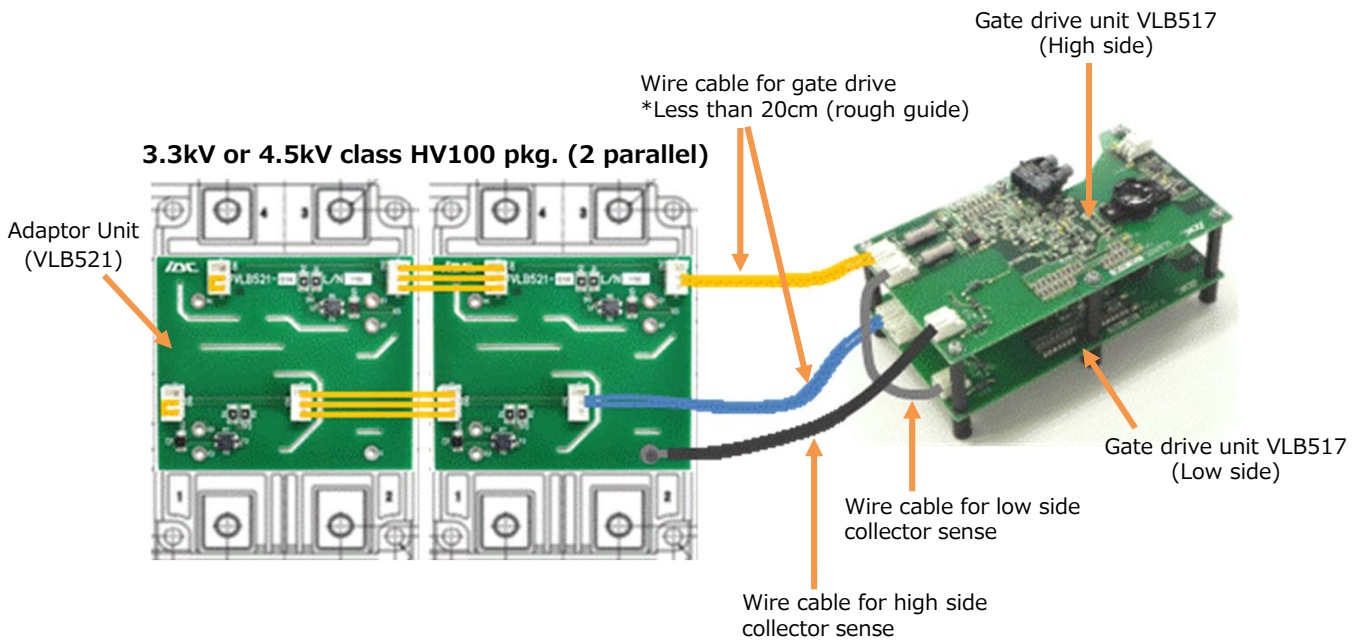

Note) When gate drive cable exceeds 20cm, please make it a twisted pair.

CONNECTION EXAMPLE3

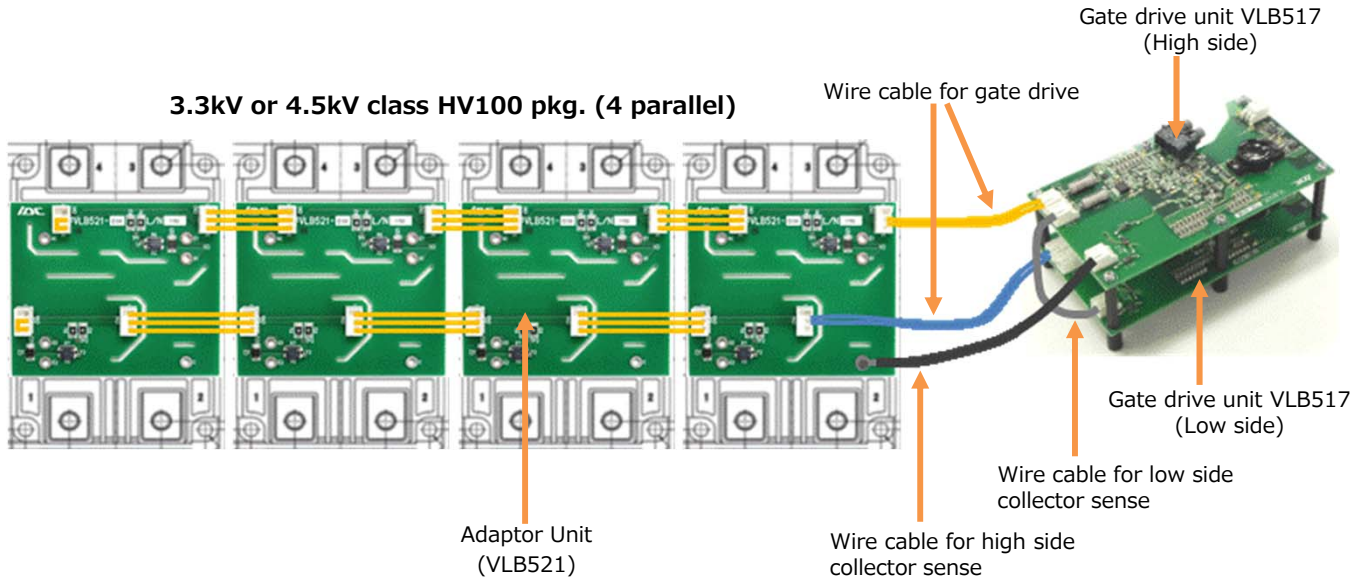

Note) When gate drive cable exceeds 20cm, please make it a twisted pair.

APPLICATION EXAMPLE1

(single connection1 of HV100)

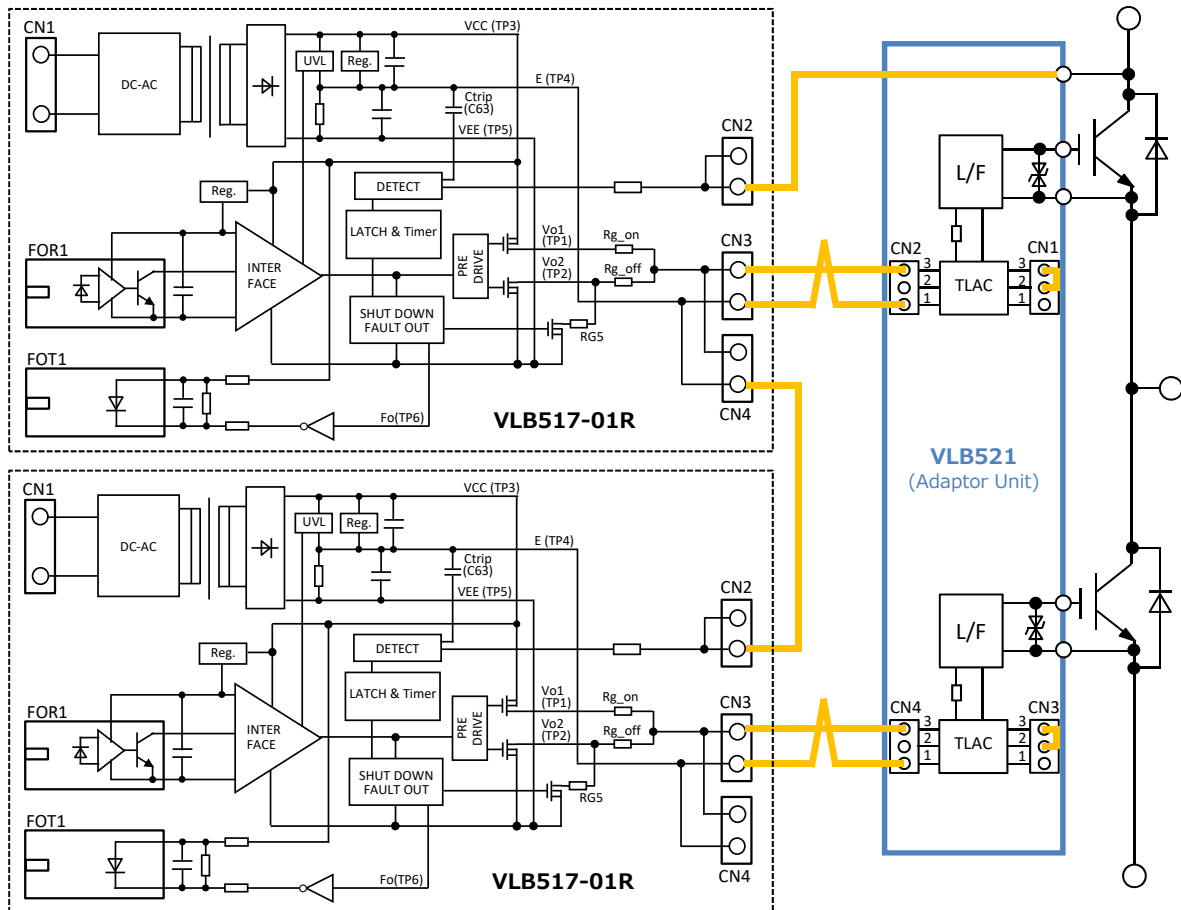

APPLICATION EXAMPLE2

(single connection2 of HV100)

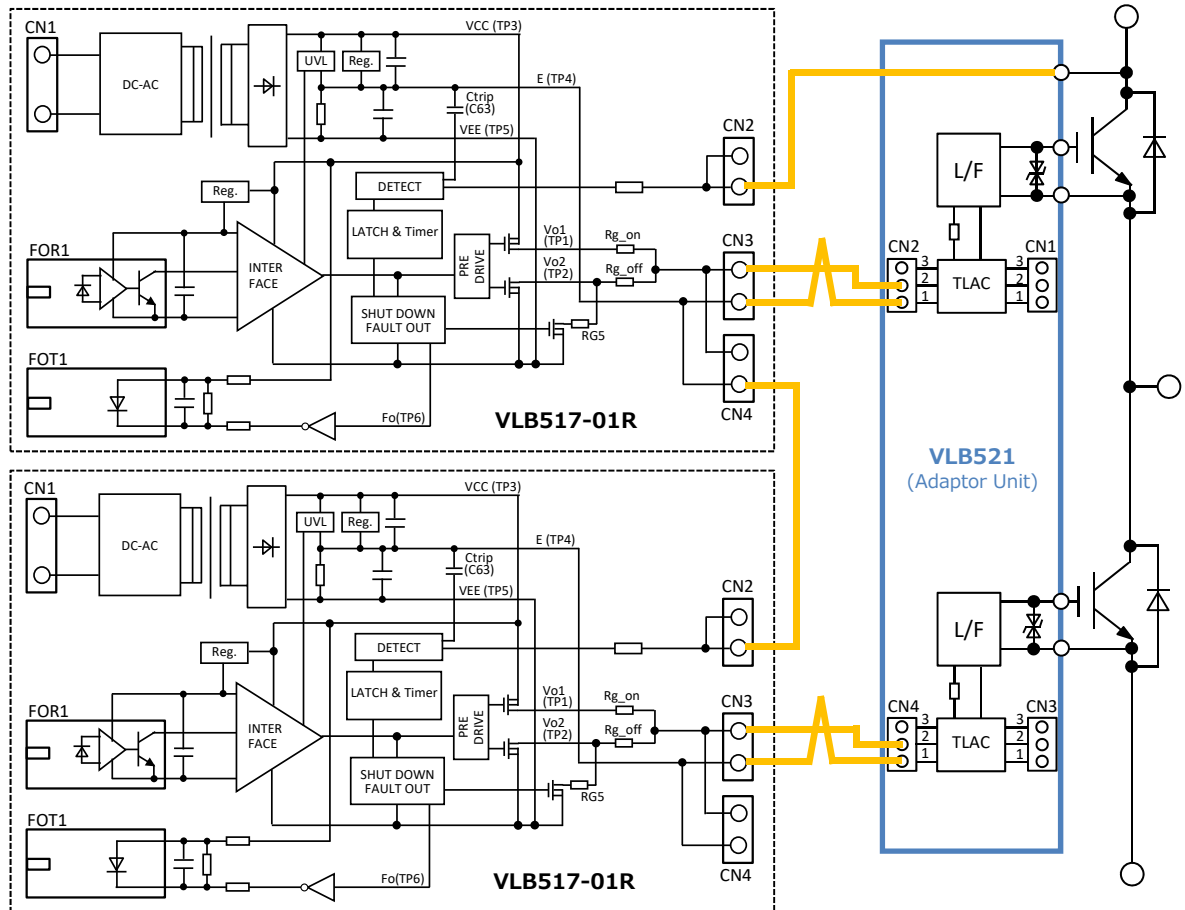

APPLICATION EXAMPLE3

(3 parallel connection of HV100)

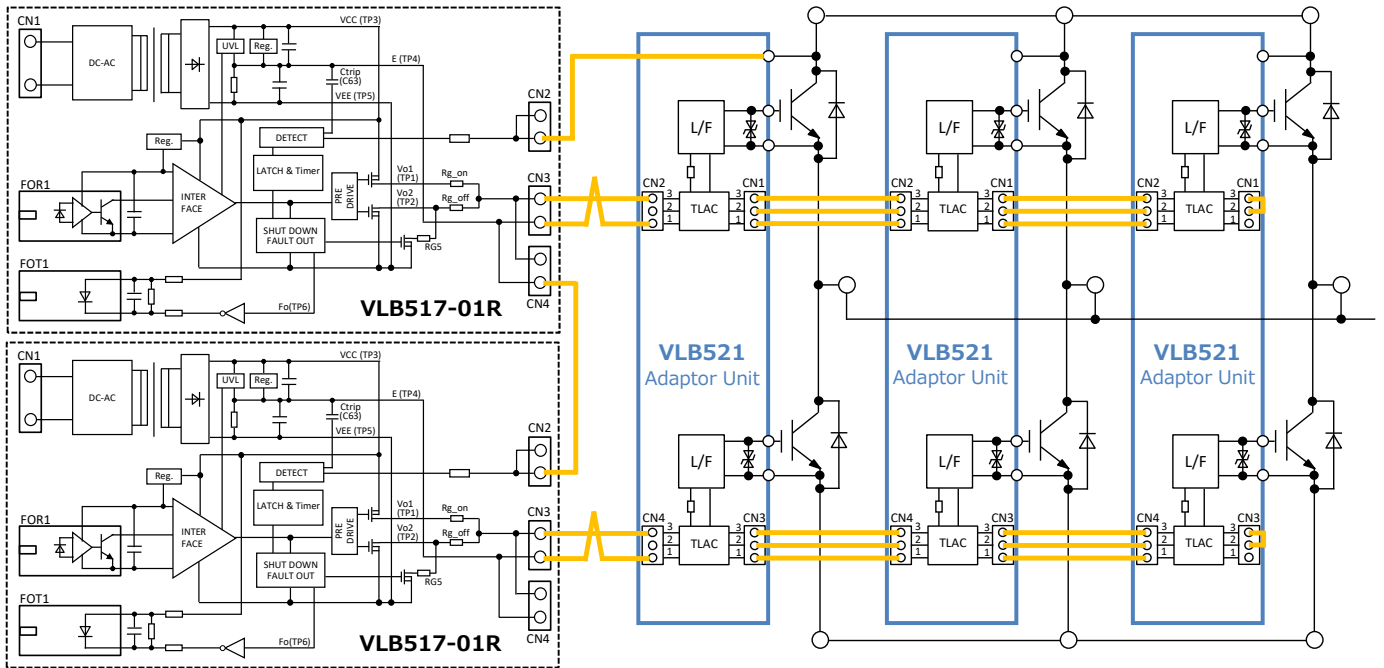

CALCULATION FOR GATE DRIVE CURRENT (GATE AVERAGE CURRENT)

This product has isolated DCDC converter built in for gate drive.
 The maximum output average current is 200mA.
 This current means maximum gate average current.
When you decide the switching frequency,
please check the gate average current by next formula.

$I_{drive} = (Q1 + |Q2|) \times f \times N$ ← **It must be less than 200mA**
 I_{drive} : Gate average current
 $Q1$: Gate charge at +15V (Read from data sheet of IGBT)
 $Q2$: Gate charge at -13V (Read from data sheet of IGBT)
 f : Switching frequency of IGBT
 N : Parallel number of IGBT module

Gate charge characteristic of IGBT

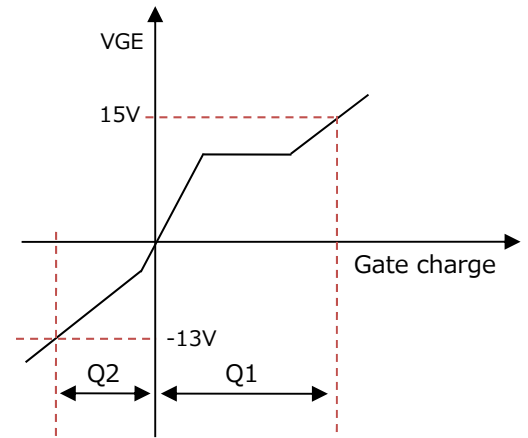

DEFINITION OF CHARACTERISTICS

Switching operation

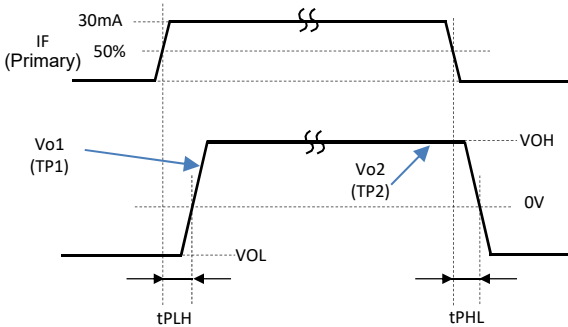

Tested by
 $f=3\text{kHz}$, Duty=50%

Operation of short circuit protection

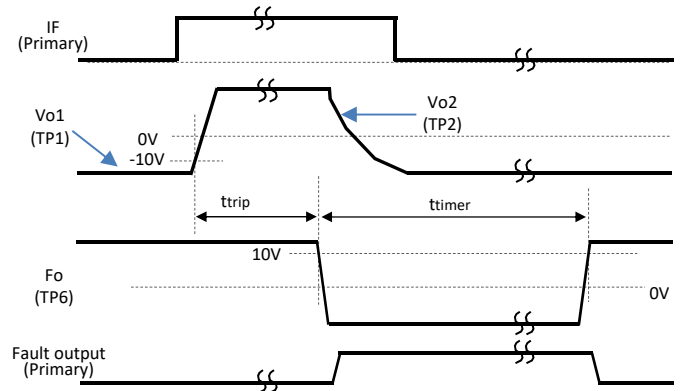

INTERFACE APPLICATION EXAMPLE

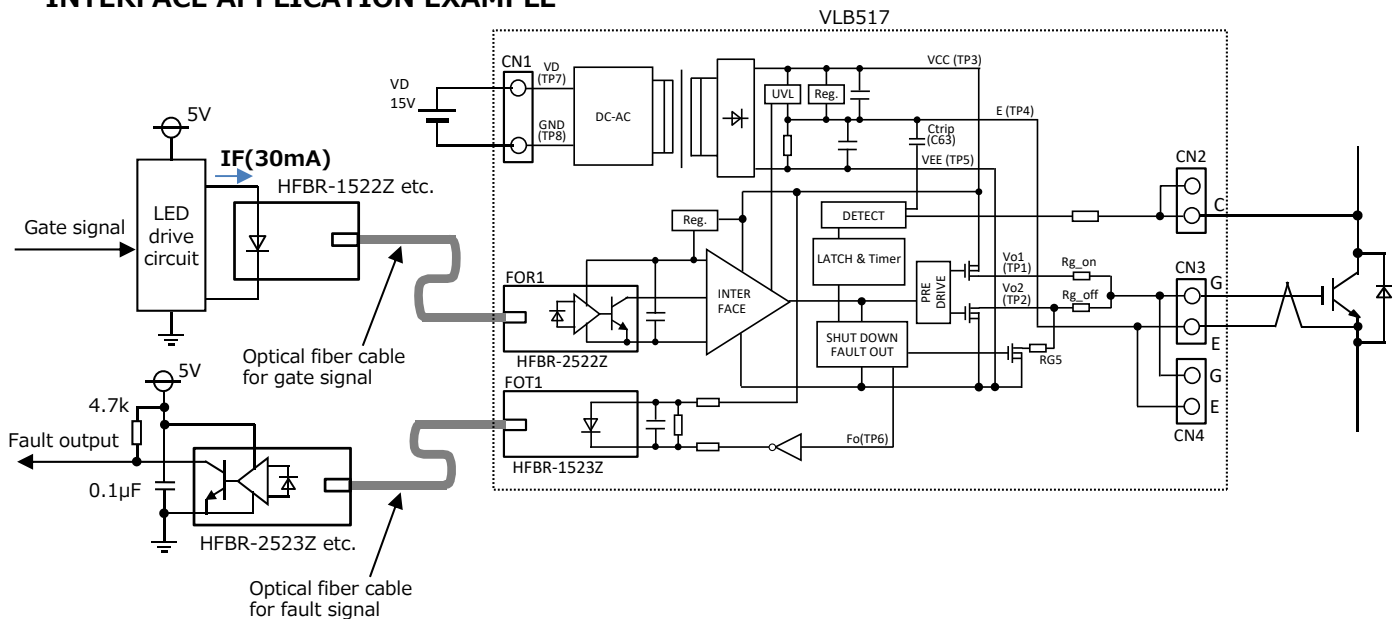

OPERATION OF PROTECTION CIRCUIT

- (1) In case the input gate signal is "ON" and the collector voltage is high, this drive unit will recognize the circuit as short circuit and reduce the gate voltage. Besides, put out fault signal ("L") which inform that protection circuit is operating at the same time from Fo terminal (Test Pad6).
- (2) The protection circuit reset and resort to ordinary condition if input signal is "OFF" when the premised 1~2msec passed. ("OFF" period needs 10us or more)
- (3) When the output rises, the masked time detect short circuit (ttrip) is set up so that on-time of IGBT can be secured properly. The ttrip can be extended by adding a capacitor to C63 on unit. (If needed C63, lough guide is 22~68pF)

LATCH & TIMER RESET SYSTEM IN SHORT CIRCUIT PROTECTION CIRCUIT

Once the short-circuit protection circuit starts, it shuts down the gate output and keeps alarm output, causing the latch status. This status is canceled if the input signal is OFF when specific time elapses after the activation of the short-circuit protection circuit. Then, gate output depending on input signals becomes possible. If the input signal is ON when specific time elapses, the latch status is not canceled: it is canceled when the signal becomes OFF.

As mentioned above, on the latch & timer reset system, the latch status is resulted after activation of the protection circuit and shutdown of the gate output. Therefore, during this period, gate output is not made no matter how much input signals are received. For this reason, it is possible to safely stop the entire equipment by sending error signals to the microcomputer during this period to stop all gate signals.

OPERATION FLOW ON DETECTING SHORT CIRCUIT

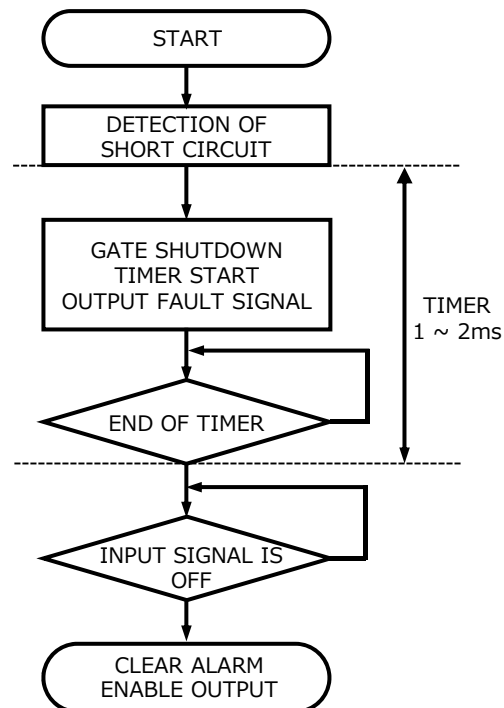

TIMING CHART

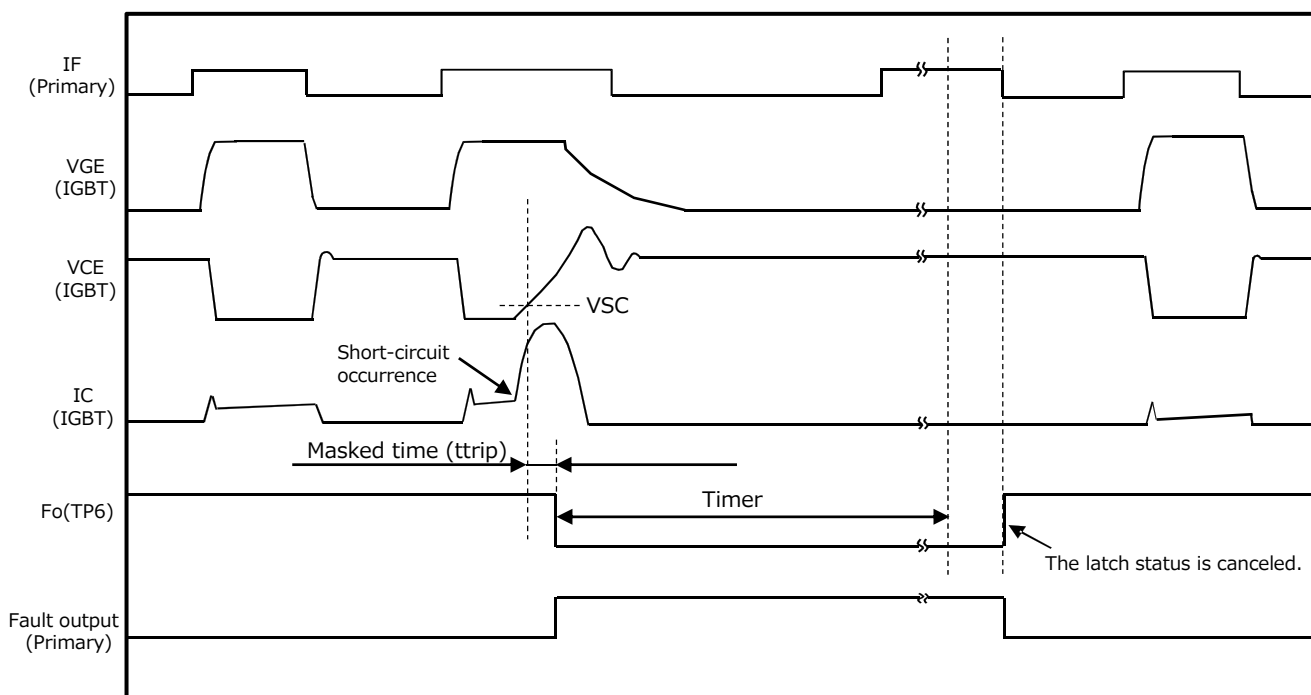

ABOUT MOUNTING GATE RESISTORS FOR NORMAL SWITCHING

There is not Gate Resistors on this unit at the initial state.
 It is possible to install up to 4 resistors in mount area of gate resistor for normal switching.
 And there are some variations by combining resistors.
 There are some examples in the following chart, please refer to it and set the gate resistors.
 And please solder the chosen resistors.

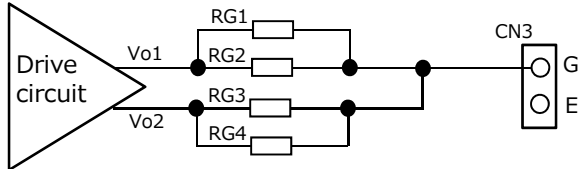

Layout pattern connection on substrate

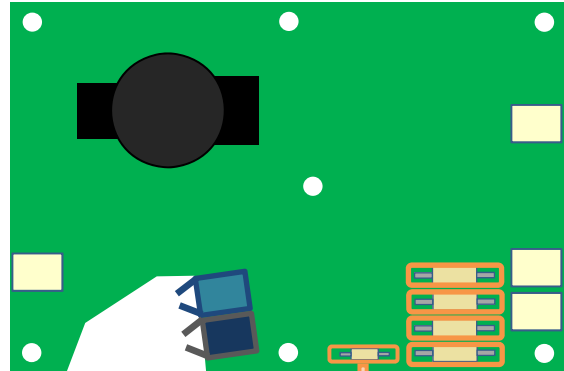

*Refer to next page

: Gate resistor mount part (Initial is open)

Example 1

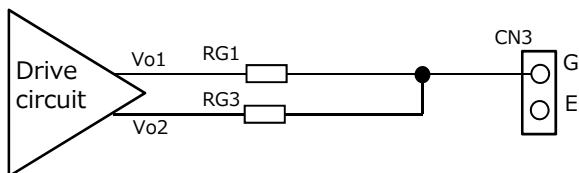

Rg_on → RG1
 Rg_off → RG3

Example 2

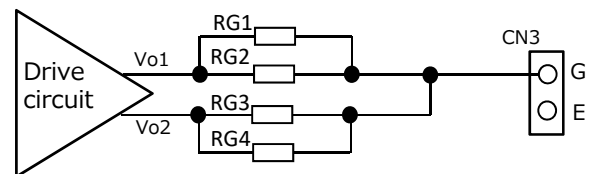

Rg_on → RG1//RG2
 Rg_off → RG3//RG4

THE WAY TO CALCULATE GATE RESISTANCE VALUE OF PARALLEL CONNECTION

RG_ON/1elem. = Gate ON resistance value per one element = $R_b + (N \times R_{g_on})$

RG_OFF/1elem. = Gate OFF resistance value per one element = $R_b + (N \times R_{g_off})$

Note) R_b : Balance resistance value on adaptor unit

N : Parallel number of modules

R_{g_on} : Gate ON resistance value on VLB517

R_{g_off} : Gate OFF resistance value on VLB517

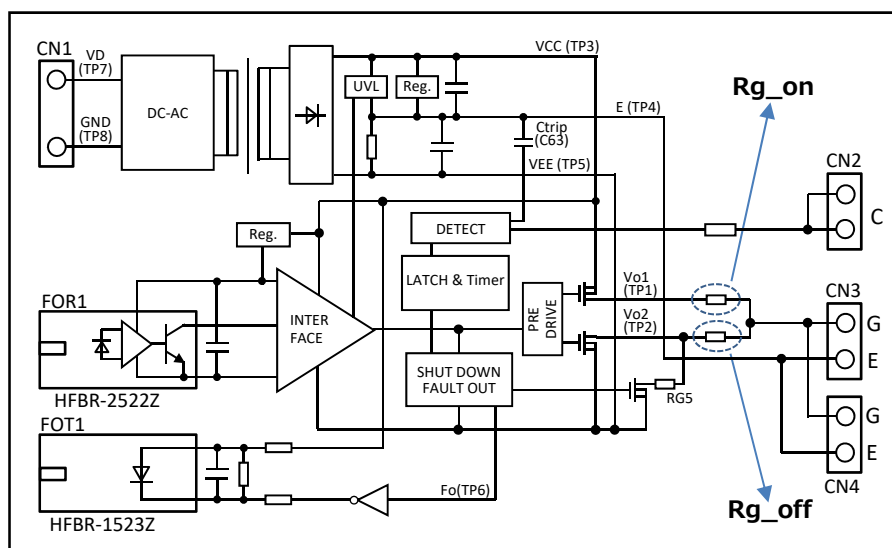

ABOUT DISCHARGE RESISTOR FOR SOFT SHUT DOWN-ON ACTIVITY OF SHORT CIRCUIT PROTECTION

When the short circuit protection works, the soft gate shut down circuit works to suppress collector surge voltage of IGBT. When short circuit protection circuit operates, the gate voltage descends slowly by the discharge circuit in dotted line of following figure.

In this figure, main discharge resistor is RG5. But RG5 is not installed in this drive unit at the initial state.

So please solder the chosen resistor(1W class) certainly.

And please set RG5 by the following equation.

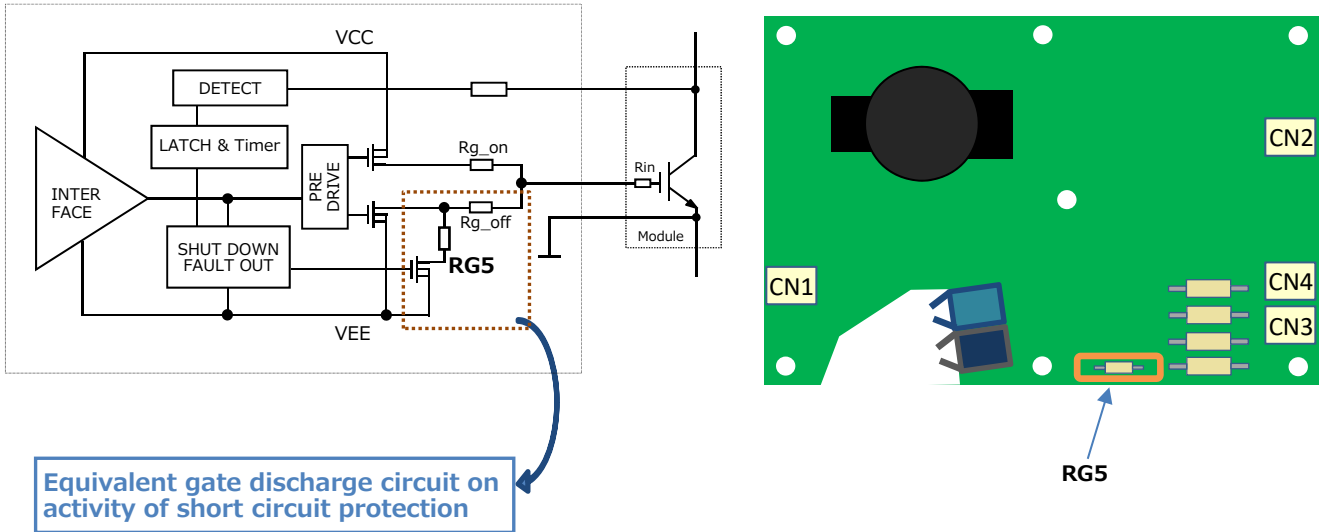

Equivalent gate discharge circuit on activity of short circuit protection

Please adjust RG5 value so that it may satisfy the next equation. (Reference guide)

$$C \times R_discharge = 2 \sim 5 \text{ (usec)}$$

$$C = N \times (Q1 + IQ2) / (VCC + IVEEI)$$

$$R_discharge = RG5 + RG_off + \frac{Rin}{N}$$

- N : Parallel number of IGBT module * If single driving, N=1
- Q1 : Gate charge at Vge=+15V (Read from data sheet of IGBT)
- Q2 : Gate charge at Vge=-13V (Read from data sheet of IGBT)
- VCC : 15
- IVEEI : 13
- R_discharge : Total discharge resistance for gate soft shut down on activity of short circuit protection
- Rin : Inner gate resistance of IGBT module

Please confirm that off surge voltage at blocking short circuit current doesn't exceed maximum rating of VCES by actual operation finally.

DETAILS OF CONNECTOR

CN1 : 53259-0229 (Molex)	
Pin No.	Signal
1	VD
2	GND

CN3: 53259-0229 (Molex)	
Pin No.	Signal
1	Emitter
2	Gate

CN2: 53259-0229 (Molex)	
Pin No.	Signal
1	Collector
2	Collector

CN4: 53259-0229 (Molex)	
Pin No.	Signal
1	Emitter
2	Gate

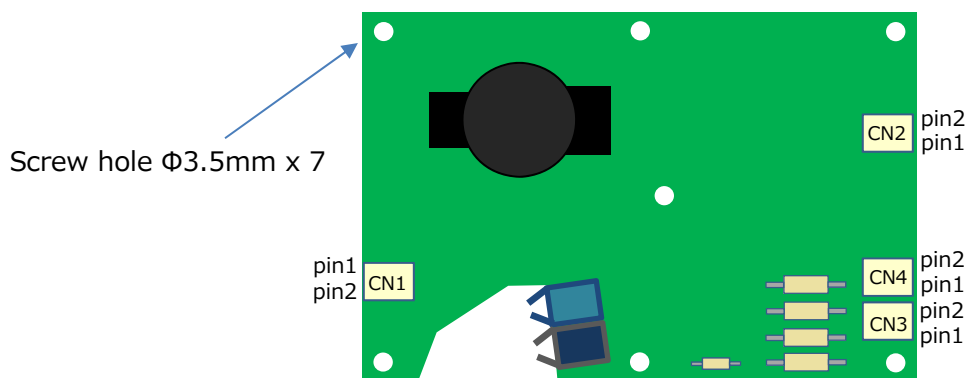

We recommend following parts or equivalent product for wire cable

HOUSING	TERMINAL	Maker
51067-0200	50217-8100	Molex

INSTALLATION OF THE DRIVE UNIT ON METALLIC CASE

When fixing this drive unit on a metallic case, please use the spacer made of the resin.

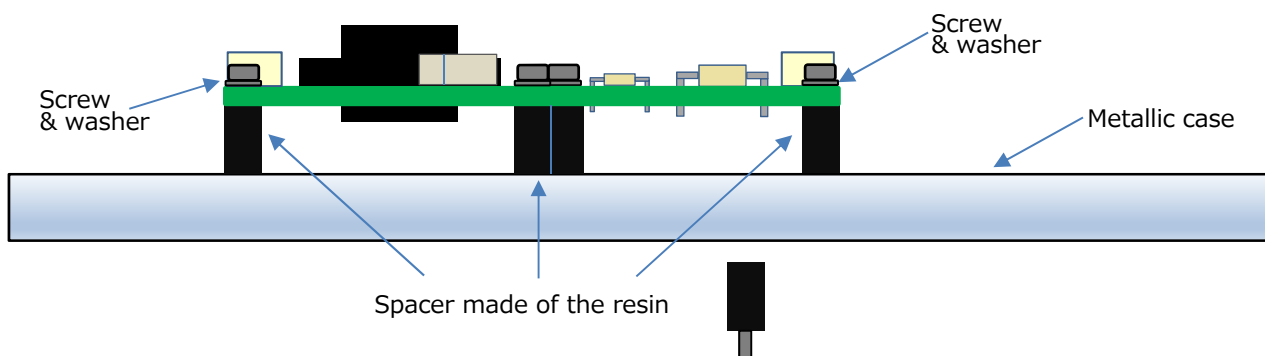

FOR SAFETY USING

Great detail and careful attention are given to the production activity of Hics, such as the development, the quality of production, and in it's reliability. However the reliability of Hics depends not only on their own factors but also in their condition of usage. When handling Hics, please note the following cautions.

CAUTIONS	
Packing	The materials used in packing Hics can only withstand normal external conditions. When exposed to outside shocks, rain and certain environmental contaminators, the packing materials will deteriorates. Please take care in handling.
Carrying	<ol style="list-style-type: none"> 1) Don't stack boxes too high. Avoid placing heavy materials on boxes. 2) Boxes must be positioned correctly during transportation to avoid breakage. 3) Don't throw or drop boxes. 4) Keep boxes dry. Avoid rain or snow. 5) Minimal vibration and shock during transportation is desirable.
Storage	<p>When storing Hics, please observe the following notices or possible deterioration of their electrical characteristics, risk of solder ability, and external damage may occur.</p> <ol style="list-style-type: none"> 1) Devices must be stored where fluctuation of temperature and humidity is minimal, and must not be exposed to direct sunlight. Store at the normal temperature of 5 to 30 degrees Celsius with humidity at 40 to 60%. 2) Avoid locations where corrosive gasses are generated or where much dust accumulates. 3) Storage cases must be static proof. 4) Avoid putting weight on boxes.
Extended storage	When extended storage is necessary, Hics must be kept non-processed. When using Hics which have been stored for more than one year or under severe conditions, be sure to check that the exterior is free from flaw and other damages.
Maximum ratings	To prevent any electrical damages, use Hics within the maximum ratings. The temperature, current, voltage, etc. must not exceed these conditions.
Polarity	To protect Hics from destruction and deterioration due to wrong insertion, make sure of polarity in inserting leads into the board holes, conforming to the external view for the terminal arrangement.

Keep safety first in your circuit designs!

·ISAHAYA Electronics Corporation puts the maximum effort into making semiconductor products better and more reliable, but there is always the possibility that trouble may occur with them. Trouble with semiconductors may lead to personal injury, fire or property damage. Remember to give due consideration to safety when making your circuit designs, with appropriate measures such as (1) placement of substitutive, auxiliary circuits, (2) use of non-flammable material or (3) prevention against any malfunction or mishap.

Notes regarding these materials

·These materials are intended as a reference to our customers in the selection of the ISAHAYA products best suited to the customer's application; they don't convey any license under any intellectual property rights, or any other rights, belonging to ISAHAYA or a third party.

·ISAHAYA Electronics Corporation assumes no responsibility for any damage, or infringement of any third party's rights, originating in the use of any product data, diagrams, charts or circuit application examples contained in these materials.

·All information contained in these materials, including product data, diagrams and charts, represent information on products at the time of publication of these materials, and are subject to change by ISAHAYA Electronics Corporation without notice due to product improvements or other reasons.

It is therefore recommended that customers contact ISAHAYA Electronics Corporation or an authorized ISAHAYA products distributor for the latest product information before purchasing product listed herein.

·ISAHAYA Electronics Corporation products are not designed or manufactured for use in a device or system that is used under circumstances in which human life is potentially at stake. Please contact ISAHAYA Electronics Corporation or an authorized ISAHAYA products distributor when considering the use of a product contained herein for any specific purposes, such as apparatus or systems for transportation, vehicular, medical, aerospace, nuclear, or undersea repeater use.

·The prior written approval of ISAHAYA Electronics Corporation is necessary to reprint or reproduce in whole or in part these materials.

·If these products or technologies are subject to the Japanese export control restrictions, they must be exported under a license from the Japanese government and cannot be imported into a country other than the approved destination.

Any diversion or re-export contrary to the export control laws and regulations of Japan and/or the country of destination is prohibited.

·Please contact ISAHAYA Electronics Corporation or authorized ISAHAYA products distributor for further details on these materials or the products contained therein.